

Fluid Cooling Shell & Tube B / SB Series

Performance Notes

- Young Touchstone thermal interchange
- Competitively priced
- 1/4" or 3/8" tubes available
- Water to water applications
- Sea water applications
- NPT, SAE O-Ring, SAE flange, or BSPP shell side connections available
- End bonnets removable for servicing
- Mounting feet included (may be rotated in 90° increments)



Options
90/10 copper nickel cooling tubes, bronze end bonnets for sea water service and zinc anodes

Ratings

Maximum Operating Pressure - Shell Side
250 PSI

Maximum Operating Pressure - Tube Side
150 PSI

Maximum Operating Temperature
350°F

Materials

- Tubes** Copper
- Hubs & Tubesheets** Steel or brass
- Shell** Steel or brass
- Baffles** Brass
- End Bonnets** Cast iron
- Mounting Brackets** Steel
- Gaskets** Nitrile rubber/cellulose fiber
- Nameplate** Aluminum foil

How to Order

<input type="text"/>	-	<input type="text"/>	-	<input type="text"/>	-	<input type="text"/>	-	<input type="text"/>	-	<input type="text"/>	-	<input type="text"/>	-	<input type="text"/>		
Model Series		Model Size Selected		Baffle Spacing		Tube Diameter Code		Tubeside Passes		Shell Material		Cooling Tube Material		End Bonnet Material		Zinc Anodes
SB SBF B BS BM BF BFM				A - 1.125 B - 2.25 C - 4.5 D - 9.0		4 - 1/4" 6 - 3/8"		O - One Pass T - Two Pass F - Four Pass		Blank - Steel BR - Brass		Blank - Copper CN - CuNi		Blank - Cast Iron B - Bronze		Blank - None Z - Zinc

ADD FOR B SERIES MODELS ONLY:
BR-CN-B-Z is to be used for all seawater/dirty water applications.

Steel Hub

- SB** = NPT Shell Side, NPT Tube Side
- SBF** = SAE Flange (with UNC threads) Shell Side connections; NPT Tube Side connections

Brass Hub

- B** = NPT Shell Side connections; NPT Tube Side connections
- BS** = SAE O-Ring Shell Side connections; NPT Tube Side connections
- BM** = BSPP Shell Side connections; BSPP Tube Side connections
- BF** = SAE Flange (with UNC threads) Shell Side connections; NPT Tube Side connections
- BFM** = SAE Flange (with Metric threads) Shell Side connections; BSPP Tube Side connections

SAE flanges available on some models. Consult factory for details.

Dimensions

One Pass

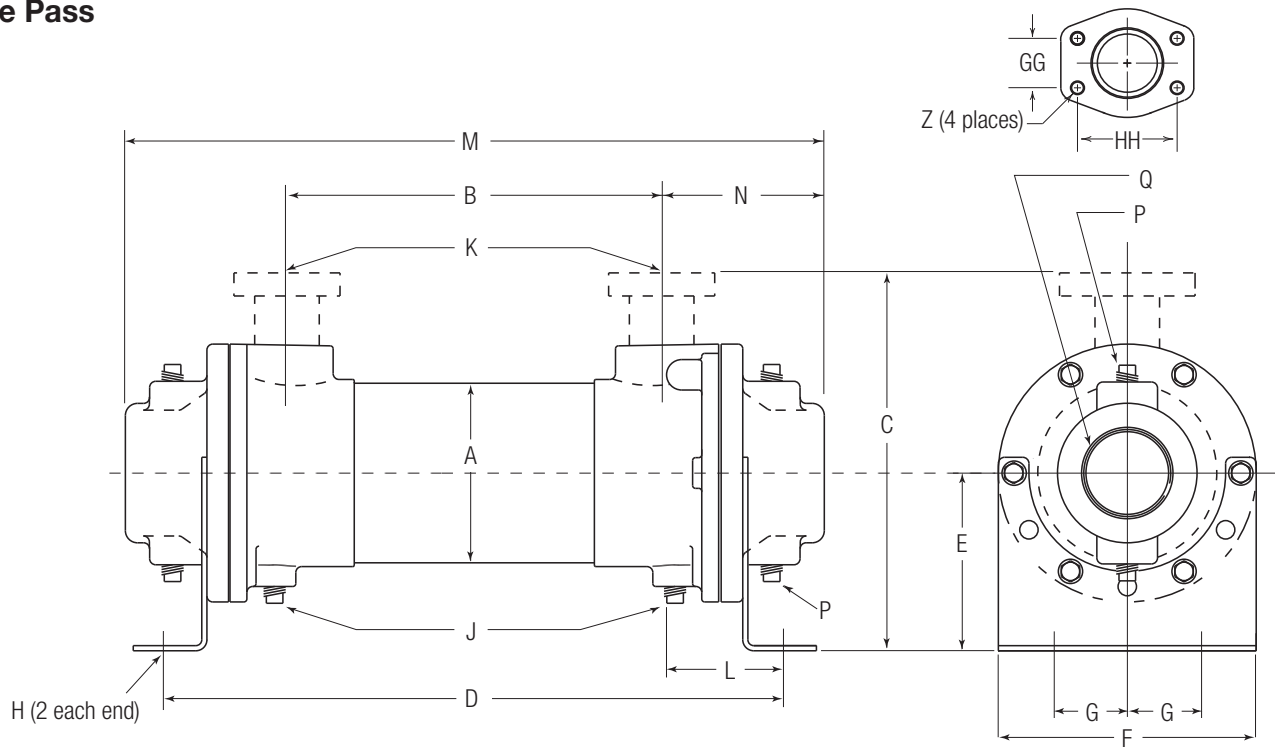

Flange Size	GG	HH	Z - CF	Z - CFM
1	1.03	2.06	3/8-16 UNC	M-10
1.50	1.41	2.75	1/2-13 UNC	M-12
2	1.69	3.06	1/2-13 UNC	M-12
3	2.44	4.19	5/8-11 UNC	M-16

Model	A	B	C		D	E	F	G	H	J NPT	K		L	M	N	P NPT	Q NPT
			NPT/BSPP SAE O-Ring	SAE Flange							NPT/BSPP Flange	SAE O-Ring					
B-401	2.125	7.62	3.50	—	11.01	1.94	2.62	.88	.41 Dia.	—	*.50	#8, 3/4-16 UNF-2B	1.72	11.24	1.81	—	1.00
B-402	2.125	16.62	3.50	—	20.01	1.94	2.62	.88	.41 Dia.	—	*.50	#8, 3/4-16 UNF-2B	1.72	20.24	1.81	—	1.00
B-701	3.656	7.00	6.25	C/F	12.01	3.62	5.25	1.50	.44 x 1.00	(2) .38	1.00	#16 1 1/16-12 UNF-2B	2.69	13.64	3.24	(4) .38	1.50
B-702	3.656	16.00	6.25	C/F	21.01	3.62	5.25	1.50	.44 x 1.00	(2) .38	1.00	#16 1 1/16-12 UNF-2B	2.69	22.64	3.24	(4) .38	1.50
B-703	3.656	25.00	6.25	C/F	30.01	3.62	5.25	1.50	.44 x 1.00	(2) .38	1.00	#16 1 1/16-12 UNF-2B	2.69	31.64	3.24	(4) .38	1.50
B-1002	5.125	15.50	7.38	8.46	21.71	4.00	6.75	2.00	.44 x 1.00	(6) .38	1.50	#24 1 7/8-12 UN-2B	3.06	23.60	4.05	(4) .38	2.00
B-1003	5.125	24.50	7.38	8.46	30.71	4.00	6.75	2.00	.44 x 1.00	(6) .38	1.50	#24 1 7/8-12 UN-2B	3.06	32.60	4.05	(4) .38	2.00
B-1004	5.125	33.50	7.38	8.46	39.71	4.00	6.75	2.00	.44 x 1.00	(6) .38	1.50	#24 1 7/8-12 UN-2B	3.06	41.60	4.05	(4) .38	2.00
B-1202	6.125	14.62	8.81	10.50	21.50	4.75	7.50	2.50	.44 x .88	(6) .38	2.00	#32 2 1/2-12 UN-2B	3.44	24.38	4.88	(4) .50	3.00
B-1203	6.125	23.50	8.81	10.50	30.38	4.75	7.50	2.50	.44 x .88	(6) .38	2.00	#32 2 1/2-12 UN-2B	3.44	33.25	4.88	(4) .50	3.00
B-1204	6.125	32.38	8.81	10.50	39.25	4.75	7.50	2.50	.44 x .88	(6) .38	2.00	#32 2 1/2-12 UN-2B	3.44	42.12	4.88	(4) .50	3.00
B-1205	6.125	41.38	8.81	10.50	48.25	4.75	7.50	2.50	.44 x .88	(6) .38	2.00	#32 2 1/2-12 UN-2B	3.44	51.12	4.88	(4) .50	3.00
B-1206	6.125	50.50	8.81	10.50	57.38	4.75	7.50	2.50	.44 x .88	(6) .38	2.00	#32 2 1/2-12 UN-2B	3.44	60.25	4.88	(4) .50	3.00
B-1207	6.125	59.50	8.81	10.50	66.38	4.75	7.50	2.50	.44 x .88	(6) .38	2.00	#32 2 1/2-12 UN-2B	3.44	69.25	4.88	(4) .50	3.00
B-1208	6.125	38.38	8.81	10.50	75.25	4.75	7.50	2.50	.44 x .88	(6) .38	2.00	#32 2 1/2-12 UN-2B	3.44	78.12	4.88	(4) .50	3.00
B-1602	8.00	13.60	12.13	15.61	22.38	6.50	8.62	3.50	.44 x 1.00	(6) .38	3.00	—	4.39	26.62	6.52	(4) .50	4.00
B-1603	8.00	22.60	12.13	15.61	31.38	6.50	8.62	3.50	.44 x 1.00	(6) .38	3.00	—	4.39	35.62	6.52	(4) .50	4.00
B-1604	8.00	31.60	12.13	15.61	40.38	6.50	8.62	3.50	.44 x 1.00	(6) .38	3.00	—	4.39	44.62	6.52	(4) .50	4.00
B-1605	8.00	40.60	12.13	15.61	49.38	6.50	8.62	3.50	.44 x 1.00	(6) .38	3.00	—	4.39	53.62	6.52	(4) .50	4.00
B-1606	8.00	49.60	12.13	15.61	58.38	6.50	8.62	3.50	.44 x 1.00	(6) .38	3.00	—	4.39	62.62	6.52	(4) .50	4.00
B-1607	8.00	58.60	12.13	15.61	67.38	6.50	8.62	3.50	.44 x 1.00	(6) .38	3.00	—	4.39	71.62	6.52	(4) .50	4.00
B-1608	8.00	67.60	12.13	15.61	76.38	6.50	8.62	3.50	.44 x 1.00	(6) .38	3.00	—	4.39	80.62	6.52	(4) .50	4.00
B-1609	8.00	76.60	12.13	15.61	85.38	6.50	8.62	3.50	.44 x 1.00	(6) .38	3.00	—	4.39	89.62	6.52	(4) .50	4.00
B-1610	8.00	85.60	12.13	15.61	94.38	6.50	8.62	3.50	.44 x 1.00	(6) .38	3.00	—	4.39	98.62	6.52	(4) .50	4.00

*B-401 and B-402 SAE Flange not available. NOTE: We reserve the right to make reasonable design changes without notice. Consult factory. All dimensions are inches.

Dimensions

Two Pass

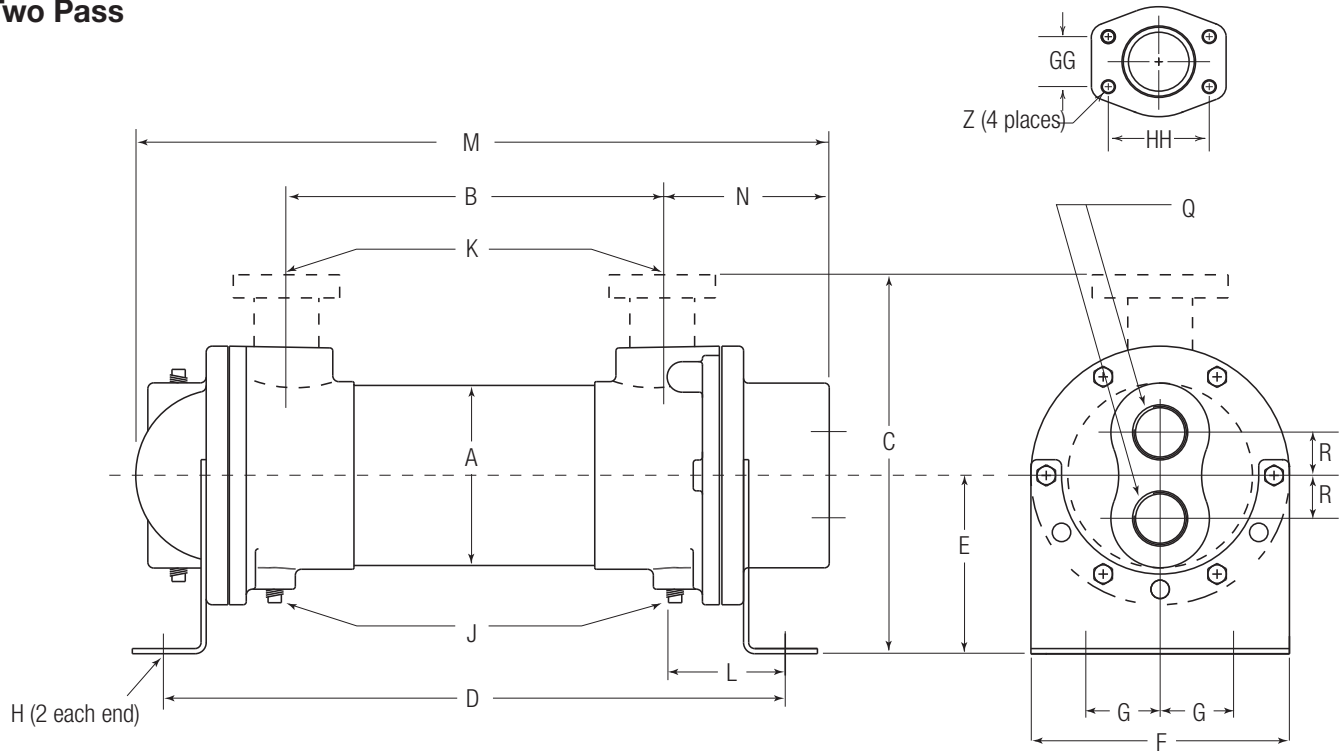

Flange Size	GG	HH	Z - CF	Z - CFM
1	1.03	2.06	3/8-16 UNC	M-10
1.50	1.41	2.75	1/2-13 UNC	M-12
2	1.69	3.06	1/2-13 UNC	M-12
3	2.44	4.19	5/8-11 UNC	M-16

Model	A	B	C		D	E	F	G	H	J NPT	K		L	M	N	P NPT	Q NPT	R
			NPT/BSPP SAE O-Ring	SAE Flange							NPT/BSPP Flange	SAE O-Ring						
B-701	3.656	7.00	6.25	C/F	12.01	3.62	5.25	1.50	.44 x 1.00	(2) .38	1.00	#16	2.69	13.28	3.30	(2) .38	1.00	.88
B-702	3.656	16.00	6.25	C/F	21.01	3.62	5.25	1.50	.44 x 1.00	(2) .38	1.00	1 1/16-12 UNF-2B	2.69	22.28	3.30	(2) .38	1.00	.88
B-703	3.656	25.00	6.25	C/F	30.01	3.62	5.25	1.50	.44 x 1.00	(2) .38	1.00	UNF-2B	2.69	31.28	3.30	(2) .38	1.00	.88
B-1002	5.125	15.50	7.38	8.46	21.71	4.00	6.75	2.00	.44 x 1.00	(6) .38	1.50	#24	3.06	23.29	3.80	(2) .38	1.50	1.19
B-1003	5.125	24.50	7.38	8.46	30.71	4.00	6.75	2.00	.44 x 1.00	(6) .38	1.50	1 1/8-12 UN-2B	3.06	32.29	3.80	(2) .38	1.50	1.19
B-1004	5.125	33.50	7.38	8.46	39.71	4.00	6.75	2.00	.44 x 1.00	(6) .38	1.50	UN-2B	3.06	41.29	3.80	(2) .38	1.50	1.19
B-1202	6.125	14.62	8.81	10.50	21.50	4.75	7.50	2.50	.44 x .88	(6) .38	2.00	#32 2 1/2-12 UN-2B	3.44	23.94	4.56	(2) .50	2.00	1.44
B-1203	6.125	23.50	8.81	10.50	30.38	4.75	7.50	2.50	.44 x .88	(6) .38	2.00		3.44	32.81	4.56	(2) .50	2.00	1.44
B-1204	6.125	32.38	8.81	10.50	39.25	4.75	7.50	2.50	.44 x .88	(6) .38	2.00		3.44	41.69	4.56	(2) .50	2.00	1.44
B-1205	6.125	41.38	8.81	10.50	48.25	4.75	7.50	2.50	.44 x .88	(6) .38	2.00		3.44	50.69	4.56	(2) .50	2.00	1.44
B-1206	6.125	50.50	8.81	10.50	57.38	4.75	7.50	2.50	.44 x .88	(6) .38	2.00		3.44	59.81	4.56	(2) .50	2.00	1.44
B-1207	6.125	59.50	8.81	10.50	66.38	4.75	7.50	2.50	.44 x .88	(6) .38	2.00		3.44	68.81	4.56	(2) .50	2.00	1.44
B-1208	6.125	38.38	8.81	10.50	75.25	4.75	7.50	2.50	.44 x .88	(6) .38	2.00		3.44	77.69	4.56	(2) .50	2.00	1.44
B-1602	8.00	13.60	12.13	15.61	22.38	6.50	8.62	3.50	.44 x 1.00	(6) .38	3.00		—	4.39	25.10	6.08	(2) .50	2.50
B-1603	8.00	22.60	12.13	15.61	31.38	6.50	8.62	3.50	.44 x 1.00	(6) .38	3.00	—	4.39	34.10	6.08	(2) .50	2.50	1.88
B-1604	8.00	31.60	12.13	15.61	40.38	6.50	8.62	3.50	.44 x 1.00	(6) .38	3.00	—	4.39	43.10	6.08	(2) .50	2.50	1.88
B-1605	8.00	40.60	12.13	15.61	49.38	6.50	8.62	3.50	.44 x 1.00	(6) .38	3.00	—	4.39	52.10	6.08	(2) .50	2.50	1.88
B-1606	8.00	49.60	12.13	15.61	58.38	6.50	8.62	3.50	.44 x 1.00	(6) .38	3.00	—	4.39	61.10	6.08	(2) .50	2.50	1.88
B-1607	8.00	58.60	12.13	15.61	67.38	6.50	8.62	3.50	.44 x 1.00	(6) .38	3.00	—	4.39	70.10	6.08	(2) .50	2.50	1.88
B-1608	8.00	67.60	12.13	15.61	76.38	6.50	8.62	3.50	.44 x 1.00	(6) .38	3.00	—	4.39	79.10	6.08	(2) .50	2.50	1.88
B-1609	8.00	76.60	12.13	15.61	85.38	6.50	8.62	3.50	.44 x 1.00	(6) .38	3.00	—	4.39	88.10	6.08	(2) .50	2.05	1.88
B-1610	8.00	85.60	12.13	15.61	94.38	6.50	8.62	3.50	.44 x 1.00	(6) .38	3.00	—	4.39	97.10	6.08	(2) .50	2.50	1.88

NOTE: We reserve the right to make reasonable design changes without notice. Consult factory. All dimensions are inches.

Dimensions

Four Pass

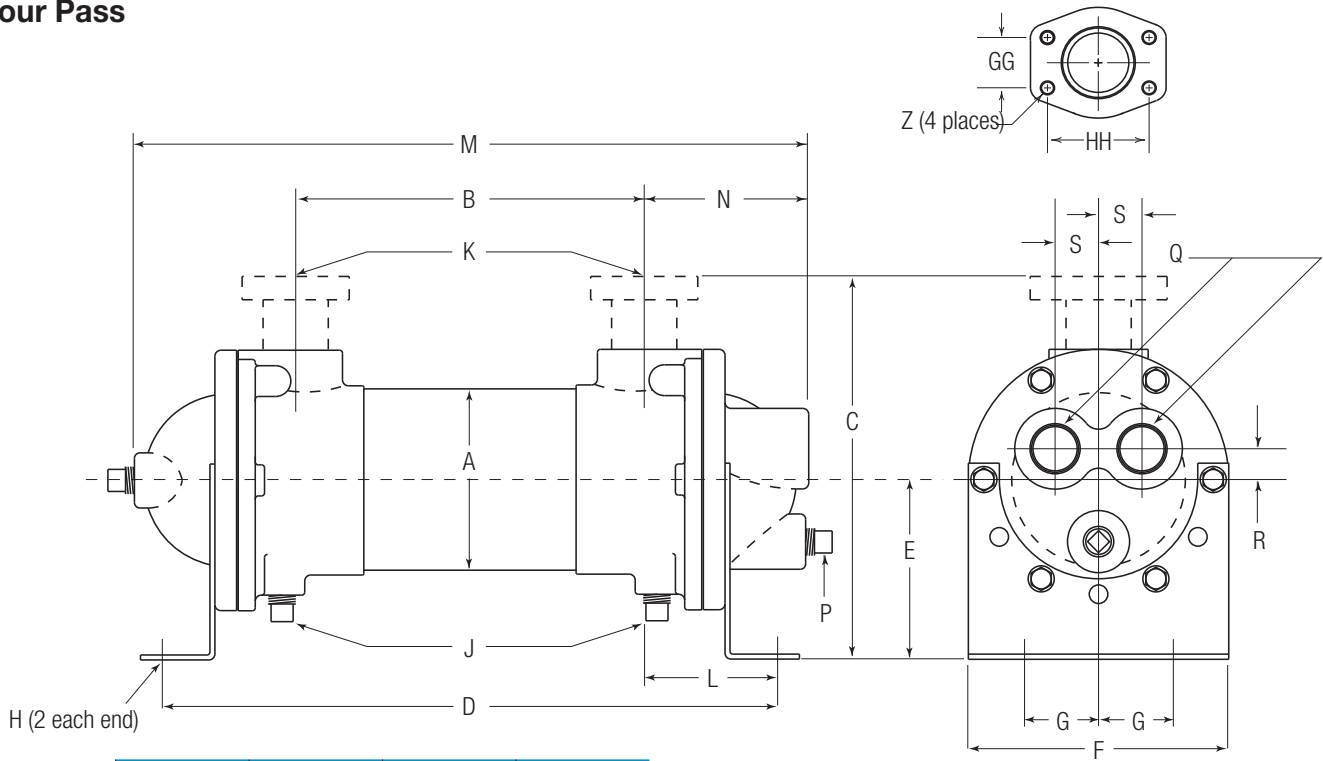

Flange Size	GG	HH	Z - CF	Z - CFM
1	1.03	2.06	3/8-16 UNC	M-10
1.50	1.41	2.75	1/2-13 UNC	M-12
2	1.69	3.06	1/2-13 UNC	M-12
3	2.44	4.19	5/8-11 UNC	M-16

Model	A	B	C		D	E	F	G	H	J NPT	K		L	M	N	P NPT	Q NPT	R	S
			NPT/BSPP SAE O-Ring	SAE Flange							NPT/BSPP Flange	SAE O-Ring							
B-701	3.656	7.00	6.25	C/F	12.01	3.62	5.25	1.50	.44 x 1.00	(2) .38	1.00	#16	2.69	13.57	3.32	(3) .38	.75	.62	.88
B-702	3.656	16.00	6.25	C/F	21.01	3.62	5.25	1.50	.44 x 1.00	(2) .38	1.00	1 1/16-12 UNF-2B	2.69	22.57	3.32	(3) .38	.75	.62	.88
B-703	3.656	25.00	6.25	C/F	30.01	3.62	5.25	1.50	.44 x 1.00	(2) .38	1.00	UNF-2B	2.69	31.57	3.32	(3) .38	.75	.62	.88
B-1002	5.125	15.50	7.38	8.46	21.71	4.00	6.75	2.00	.44 x 1.00	(6) .38	1.50	#24	3.06	23.57	4.12	(3) .38	1.00	.75	1.34
B-1003	5.125	24.50	7.38	8.46	30.71	4.00	6.75	2.00	.44 x 1.00	(6) .38	1.50	1 1/8-12 UN-2B	3.06	32.57	4.12	(3) .38	1.00	.75	1.34
B-1004	5.125	33.50	7.38	8.46	39.71	4.00	6.75	2.00	.44 x 1.00	(6) .38	1.50	UN-2B	3.06	41.57	4.12	(3) .38	1.00	.75	1.34
B-1202	6.125	14.62	8.81	10.50	21.50	4.75	7.50	2.50	.44 x .88	(6) .38	2.00	#32 2 1/2-12 UN-2B	3.44	24.44	4.90	(2) .38	1.50	1.06	1.40
B-1203	6.125	23.50	8.81	10.50	30.38	4.75	7.50	2.50	.44 x .88	(6) .38	2.00		3.44	33.31	4.90	(2) .38	1.50	1.06	1.40
B-1204	6.125	32.38	8.81	10.50	39.25	4.75	7.50	2.50	.44 x .88	(6) .38	2.00		3.44	42.19	4.90	(2) .38	1.50	1.06	1.40
B-1205	6.125	41.88	8.81	10.50	48.25	4.75	7.50	2.50	.44 x .88	(6) .38	2.00		3.44	51.19	4.90	(1) .50	1.50	1.06	1.40
B-1206	6.125	50.50	8.81	10.50	57.38	4.75	7.50	2.50	.44 x .88	(6) .38	2.00		3.44	60.31	4.90	(1) .50	1.50	1.06	1.40
B-1207	6.125	59.50	8.81	10.50	66.38	4.75	7.50	2.50	.44 x .88	(6) .38	2.00		3.44	69.31	4.90	(1) .50	1.50	1.06	1.40
B-1208	6.125	38.38	8.81	10.50	75.25	4.75	7.50	2.50	.44 x .88	(6) .38	2.00	3.44	78.19	4.90	(1) .50	1.50	1.06	1.40	
B-1602	8.00	13.60	12.13	15.61	22.38	6.50	8.62	3.50	.44 x 1.00	(6) .38	3.00	—	4.39	26.72	6.48	(3) .50	2.00	1.88	1.88
B-1603	8.00	22.60	12.13	15.61	31.88	6.50	8.62	3.50	.44 x 1.00	(6) .38	3.00	—	4.39	35.72	6.48	(3) .50	2.00	1.88	1.88
B-1604	8.00	31.60	12.13	15.61	40.38	6.50	8.62	3.50	.44 x 1.00	(6) .38	3.00	—	4.39	44.72	6.48	(3) .50	2.00	1.88	1.88
B-1605	8.00	40.60	12.13	15.61	49.38	6.50	8.62	3.50	.44 x 1.00	(6) .38	3.00	—	4.39	53.72	6.48	(3) .50	2.00	1.88	1.88
B-1606	8.00	49.60	12.13	15.61	58.38	6.50	8.62	3.50	.44 x 1.00	(6) .38	3.00	—	4.39	62.72	6.48	(3) .50	2.00	1.88	1.88
B-1607	8.00	58.60	12.13	15.61	67.38	6.50	8.62	3.50	.44 x 1.00	(6) .38	3.00	—	4.39	71.72	6.48	(3) .50	2.00	1.88	1.88
B-1608	8.00	67.60	12.13	15.61	76.38	6.50	8.62	3.50	.44 x 1.00	(6) .38	3.00	—	4.39	80.72	6.48	(3) .50	2.00	1.88	1.88
B-1609	8.00	76.60	12.13	15.61	85.38	6.50	8.62	3.50	.44 x 1.00	(6) .38	3.00	—	4.39	89.72	6.48	(3) .50	2.00	1.88	1.88
B-1610	8.00	85.60	12.13	15.61	94.38	6.50	8.62	3.50	.44 x 1.00	(6) .38	3.00	—	4.39	98.72	6.48	(3) .50	2.00	1.88	1.88

NOTE: We reserve the right to make reasonable design changes without notice. Consult factory. All dimensions are inches.

Performance Curves

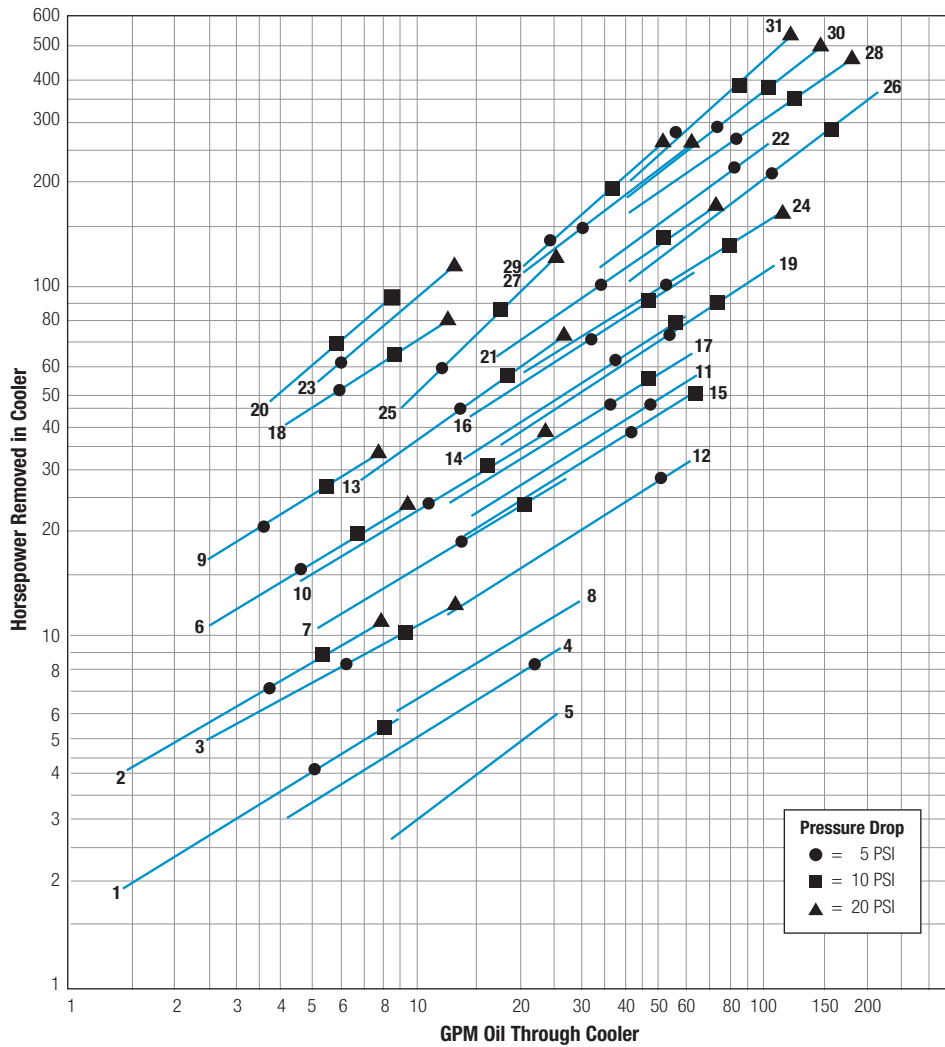

Curve Number	Model	Shipping Weight (LBS)
1	B-401-A4-0	7
2	B-402-A4-0	10
3	B-701-A4-T	23
4	B-701-B6-F	23
5	B-701-C6-T	23
6	B-702-A4-T	28
7	B-702-B4-F	28
8	B-702-C6-T	28
9	B-703-A4-T	35
10	B-703-B4-F	35
11	B-1002-C4-T	49
12	B-1002-C6-T	49
13	B-1003-B4-F	65
14	B-1003-C4-T	65
15	B-1003-C6-T	65
16	B-1004-C4-T	72
17	B-1004-C6-T	72
18	B-1202-A4-F	72
19	B-1202-C4-F	72
20	B-1204-A4-F	110
21	B-1204-C4-F	110
22	B-1206-D4-F	160
23	B-1602-A4-F	145
24	B-1602-C4-F	145
25	B-1604-B4-F	195
26	B-1604-D4-F	195
27	B-1606-C4-F	259
28	B-1606-D4-F	259
29	B-1608-C4-F	310
30	B-1608-D4-F	310
31	B-1610-D4-F	400

Shipping weights are approximate.

Maximum Flow Rates

Example Model No.
B - 1003 - C4 - F

Unit Size	Shell Side (GPM)		Baffle Spacing		Tube Side (GPM)		
	A	B	C	D	O	T	F
400	9.6	—	—	—	25	—	—
700	17	29	29	—	61	31	15
1000	24	48	69	69	146	73	37
1200	29	57	115	115	224	112	56
1600	37	74	149	253	363	181	91

Caution: Incorrect installation can cause this product to fail prematurely, causing the shell side and tube side fluids to intermix.

Piping Diagram

One Pass

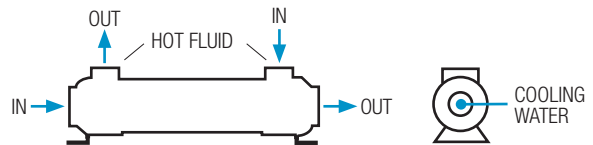

Two and Four Pass

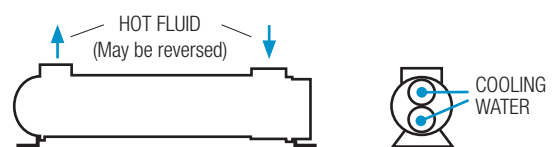

Specific applications may have different piping arrangements. Contact factory for assistance.

Selection Procedure

Performance Curves are based on 100SSU oil leaving the cooler 40°F higher than the water temperature used for cooling. This is also referred to as a 40°F approach temperature. Curves are based on a 2:1 oil to water flow ratio. Curves are 1:1.

STEP 1 Determine the Heat Load. This will vary with different systems, but typically coolers are sized to remove 25 to 50% of the input nameplate horsepower. (Example: 100 HP Power Unit x .33 = 33 HP Heat load.)
If BTU/HR is known: $HP = \frac{BTU/HR}{2545}$

STEP 2 Determine Approach Temperature. Desired oil leaving cooler °F – Water Inlet temp. °F = Actual Approach (Max. reservoir temp.)

STEP 3 Determine Curve Horsepower Heat Load. Enter the information from above:
Horsepower heat load x $\frac{40}{\text{Actual Approach}}$ x $\frac{\text{Viscosity}}{\text{Correction A}}$ = Curve Horsepower

STEP 4 Enter curves at oil flow through cooler and curve horsepower. Any curve above the intersecting point will work.

STEP 5 Determine Oil Pressure Drop from Curves:
● = 5 PSI ■ = 10 PSI ▲ = 20 PSI Multiply pressure drop from curve by correction factor B found on oil viscosity correction curve.

Viscosity Correction

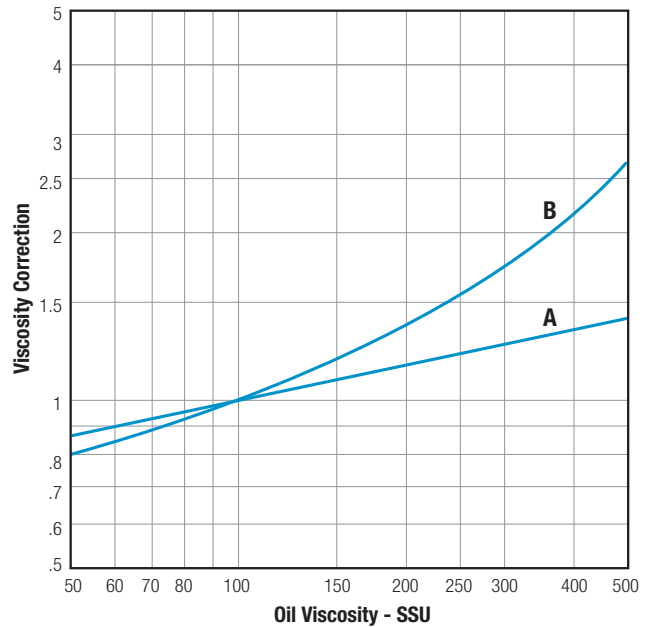

Oil Temperature

Oil coolers can be selected using entering or leaving oil temperatures.

Typical operating temperature ranges are:

Hydraulic Oil	110°F - 130°F
Hydrostatic Drive Oil	130°F - 180°F
Bearing Lube Oil	120°F - 160°F
Lube Oil Circuits	110°F - 130°F

Desired Reservoir Temperature

Return Line Cooling: Desired temperature is the oil temperature leaving the cooler. This will be the same temperature that will be found in the reservoir.

Off-Line Recirculation Cooling Loop: Desired temperature is the oil temperature *entering* the cooler. In this case, the oil temperature change must be determined so that the actual oil leaving temperature can be found. Calculate the oil temperature change (Oil ΔT) with this formula:

$$\text{Oil } \Delta T = (\text{BTUs/HR}) / (\text{GPM Oil Flow} \times 210).$$

To calculate the oil leaving temperature from the cooler, use this formula:

$$\text{Oil Leaving Temp.} = \text{Oil Entering Temp.} - \text{Oil } \Delta T.$$

This formula may also be used in any application where the only temperature available is the entering oil temperature.

Oil Pressure Drop: Most systems can tolerate a pressure drop through the heat exchanger of 20 to 30 PSI. Excessive pressure drop should be avoided. Care should be taken to limit pressure drop to 5 PSI or less for case drain applications where high back pressure may damage the pump shaft seals.

Piping Hook-up

A Series

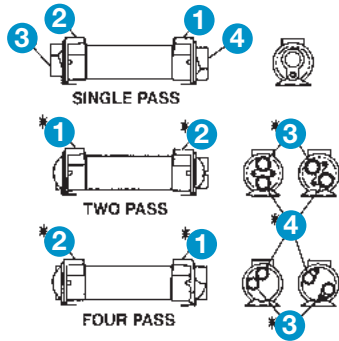

B Series

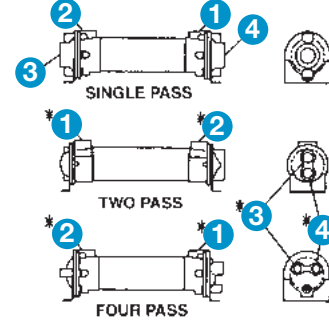

HC / SSC / EC Series

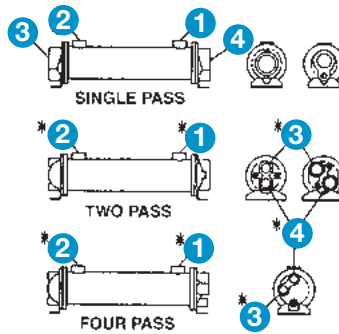

EC bonnet rotation is slightly different from what is shown. See Series literature for details.

SLE / SL / R Series

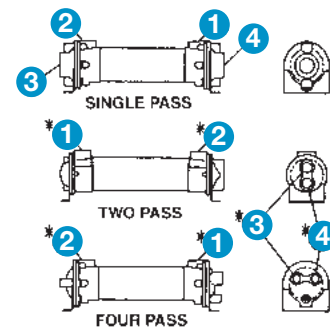

EK / EKS / EKM Series

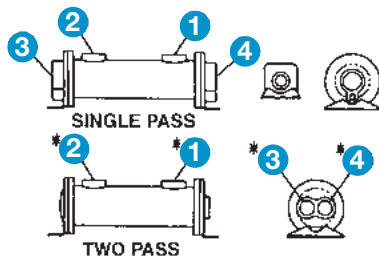

K / KN Series

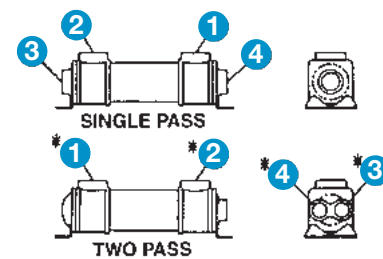

U / UC / UR Series

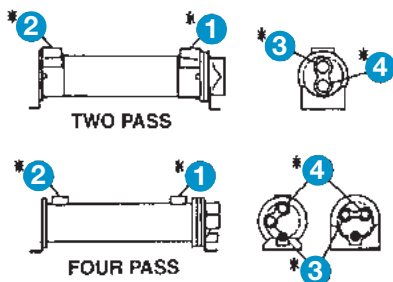

- ① Hot Fluid In
- ② Cooled Fluid Out
- ③ Cooling Water In
- ④ Cooling Water Out

*Note: For all two pass and four pass heat exchangers: connections ① and ② may be reversed, and connections ③ and ④ may be reversed with no effect on performance.

Note baffle location when inserting bundle into shell assembly after cleaning.

Installation

The satisfactory use of this heat exchange equipment is dependent upon precautions which must be taken at the time of the installation.

1. Connect and circulate the hot fluid in the shell side (over small tubes) and the cooling water in the tube side (inside small tubes). Note piping diagrams.
2. If an automatic water regulating valve is used, place it on the INLET connection of the cooler. Arrange the water outlet piping so that the exchanger remains flooded with water, but at little or no pressure. The temperature probe is placed in the hydraulic reservoir to sense a system temperature rise. Write the factory for water regulating valve recommendations.
3. There are normally no restrictions as to how this cooler may be mounted. The only limitation regarding the mounting of this equipment is the possibility of having to drain either the water or the oil chambers after the cooler has been installed. Both fluid drain plugs should be located on the bottom of the cooler to accomplish the draining of the fluids. Drains are on most models.
4. It is possible to protect your cooler from high flow and pressure surges of hot fluid by installing a fast-acting relief valve in the inlet line to the cooler.
5. It is recommended that water strainers be installed ahead of this cooler when the source of cooling water is from other than a municipal water supply. Dirt and debris can plug the water passages very quickly, rendering the cooler ineffective. Write the factory for water strainer recommendations.
6. Fixed bundle heat exchangers are generally not recommended for steam service. For steam applications, a floating bundle exchanger is required. Note: When installing floating bundle unit, secure one end firmly and opposite end loosely to allow bundle to expand and contract. Consult factory for selection assistance.
7. Piping must be properly supported to prevent excess strain on the heat exchanger ports. If excessive vibration is present, the use of shock absorbing mounts and flexible connectors is recommended.

Service

Each heat exchanger has been cleaned at the factory and should not require further treatment. It may be well to inspect the unit to be sure that dirt or foreign matter has not entered the unit during shipment. The heat exchanger should be mounted firmly in place with pipe connections tight.

Caution

If sealant tape is used on pipe threads, the degree of resistance between mating parts is less, and there is a greater chance for cracking the heat exchanger castings. Do not overtighten. When storing the unit, be sure to keep the oil and water ports sealed. If storage continues into cold winter months, the water chamber must be drained to prevent damage by freezing.

Performance information should be noted and recorded on newly installed units so that any reduction in effectiveness can be detected. Any loss in efficiency can normally be traced to an accumulation of oil sludge, or water scale.

Recommendations

Replace gaskets when removing end castings. It is recommended that gaskets be soaked in oil to prevent corrosion and ensure a tight seal.

Salt water should not be used in standard models. Use salt water in special models having 90/10 copper-nickel tubes, tube sheets*, bronze bonnets and zinc anodes on the tube side. Brackish water or other corrosive fluids may require special materials of construction.

When zinc anodes are used for a particular application, they should be inspected two weeks after initial startup.

At this time, by visual inspection of the anode, determination of future inspection intervals can be made, based on the actual corrosion rate of the zinc metal.

The zinc anodes must be replaced when 70% of the zinc volume has been consumed.

It may be necessary to drain the water chambers of the exchanger to protect it from damage by freezing temperatures. Drains are provided in most standard models.

The oil chamber of the exchanger may become filled with sludge accumulation and require cleaning. It is recommended that the unit be flooded with a commercial solvent and left to soak for one-half hour. Backflowing with the solvent or regular oil will remove most sludge. Repeated soaking and backflowing may be required, depending on the degree of sludge buildup.

It may be necessary to clean the inside of the cooling tubes to remove any contamination and/or scale buildup. It is recommended that a fifty-fifty percent solution of inhibited muriatic acid and water may be used. For severe problems, the use of a brush through the tubes may be of some help. Be sure to use a soft bristled brush to prevent scouring the tube surface causing accelerated corrosion. Upon completion of cleaning, be certain that all chemicals are removed from the shellside and the tubeside before the heat exchanger is placed into service.

When ordering replacement parts or making an inquiry regarding service, mention model number, serial number, and the original purchase order number.

**Available on HC/SSC/SSCA Series models only.*

Maximum Shell & Tube Flow Rates

CAUTION

Incorrect installation can cause this product to fail prematurely, causing the shell side and tube side fluids to intermix. Maximum allowable flow rates are as charted below.

B Series Model No. Example: B-702-A4-F

Unit Size	Shell Side (GPM) / Baffle Spacing					Tube Side (GPM)		
	A	B	C	D	E	O	T	T
400	9.6	—	—	—	—	25		
700	17	29	29	—	—	61	31	15
1000	24	48	69	69	—	146	73	37
1200	29	57	115	115	—	224	112	56
1600	37	75	149	253	—	363	181	91
2000	—	—	187	347*	457*	652	326	163

*281 GPM maximum for all B-2005-D **500 GPM maximum for all B-20080-E and 562 GPM maximum for all B2006-E6 or B-2006-E10
562 GPM maximum for all B-2006-E6 or B-2006-E10

A Series Model No. Example: A-1024-2-6-F

Unit Size	Baffle Spacing	Shell Side (GPM)	Tube Side (GPM)		
			O	T	F
SA-400	.75	7	18	—	—
	2	19			
600	1	14	48	24	12
	1.5	21			
	2	29			
800	4	29	87	43	21
	1.5	29			
	2	38			
1000	3	57	146	73	37
	4	69			
	1.5	32			
	2	42			
1200	3	60	224	112	56
	4	69			
	2	51			
	3	77			
1600	4	103	280	203	101
	6	115			
	26	66			
	3	100			
	4	133			
	6	200			

HC / SSC Series Model No. Example: HC-1024-2-6-F

Unit Size	Baffle Size	Shell Side (GPM)	Tube Side (GPM)		
			O	T	F
600	1.38	19	48	24	12
	2	29			
	3	29			
800	1.38	26	84	42	21
	1.7	31			
	2	38			
	3	57			
1000	4	69	146	23	37
	1.38	24			
	2	41			
1200	3	64	224	112	56
	5	69			
	2.5	60			
	3	77			
1700	3.62	93	465	232	116
	5	115			
	6	115			
	3.	125			
	4	143			
	4.5	161			
	5	179			
6	215				
	7	251			
	8.4	253			

EC Series Model No. Example: EC-1236-6-F

Unit Size	Baffle Size	Shell Side (GPM)	Tube Side (GPM)		
			O	T	F
1000	4	55	66	33	15
	6	70			
	8	70			
1200	4	65	120	60	28
	6	100			
	8	115			
	12	115			
1700	4	90	220	110	52
	6	140			
	8	190			
	12	255			

K / EK Series Model No. Example: EK or K-712-F

Unit Size	Shell Side (GPM)	Tube Side (GPM)	
		O	T
500	20	13	—
100	70	24	12
1000	100	56	28