

FLUID COOLING | Shell & Tube SSA Series

ALL STAINLESS STEEL CONSTRUCTION

Features

- ITT Interchange
- Type 316 Stainless Steel Construction
- Custom Designs Available
- Mounting Feet Included
(May be Rotated in 90° increments)
- End Bonnets Removable for Servicing

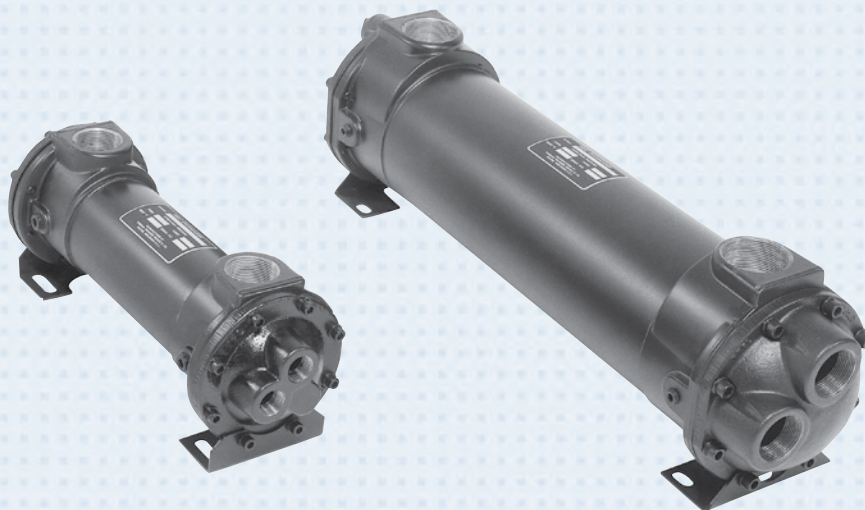

WATER COOLED SSA

Ratings

- Maximum Shell Pressure** 225 psi
- Maximum Tube Side Pressure** 150 psi
- Maximum Temperature** 450° F

Materials

- Tubes** 316 Stainless Steel
- Hubs & Tubesheets** 316 Stainless Steel
- Shell** 316 Stainless Steel
- Baffles** 316 Stainless Steel
- End Bonnets** 316 Stainless Steel
- Mounting Brackets** Steel
- Gaskets** Nitrile Rubber/Cellulose Fiber
- Nameplate** Aluminum Foil

How to Order

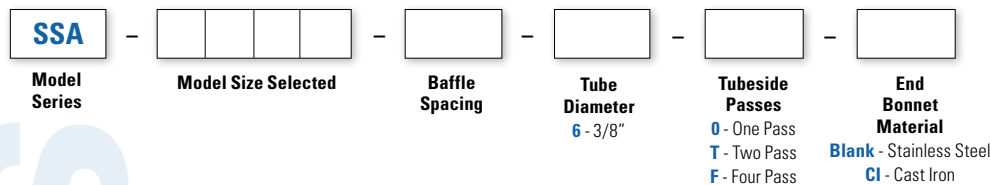

Example Model No.

SSA - 1024 - 2 - 6 - F



Dimensions

One Pass

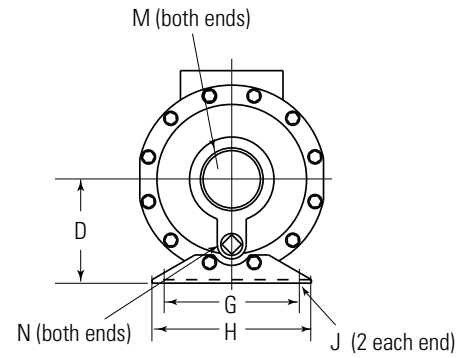
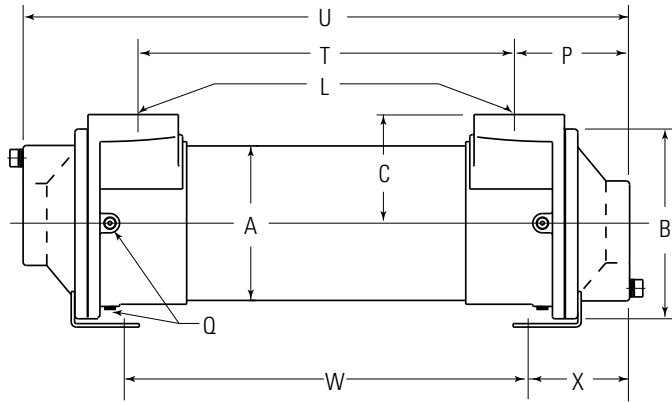

**A-1000, A-1200
& A-1600 Series**

MODEL	A DIA.	B DIA.	C	D	G	H	J	K	L NPT	M NPT	N NPT	P	Q NPT	T	U	W	X	Y
SSA-1014	5.12	6.50	3.62	3.50	4.00	5.00	.50 x .88	.12	1.50	2.50	.38	3.69	(6) .25	11.12	18.50	11.75	3.38	—
SSA-1024														21.12	28.50	21.75		
SSA-1036														33.12	40.50	33.75		
SSA-1224	6.12	7.50	4.25	4.12	5.00	6.00			2.00			4.25	(6) .25	20.50	29.00	21.50	3.75	—
SSA-1236														32.50	41.00	33.50		
SSA-1248														44.50	53.00	45.50		
SSA-1260	8.00	9.75	5.62	5.38	7.00	8.25	.62 x 1.12	.19	3.00	3.00	.50	6.00	(6) .25	19.25	31.25	20.50	5.25	—
SSA-1624														31.25	43.25	32.50		
SSA-1636														43.25	55.25	44.50		
SSA-1648	8.00	9.75	5.62	5.38	7.00	8.25	.62 x 1.12	.19	3.00	3.00	.50	6.00	(6) .25	55.25	67.25	56.50	5.25	—
SSA-1660														67.25	79.25	68.50		
SSA-1672														79.25	91.25	80.50		
SSA-1684														91.25	103.25	92.50		
SSA-1696																		

NOTE: We reserve the right to make reasonable design changes without notice. Consult factory. All dimensions are inches.

Dimensions

Two Pass

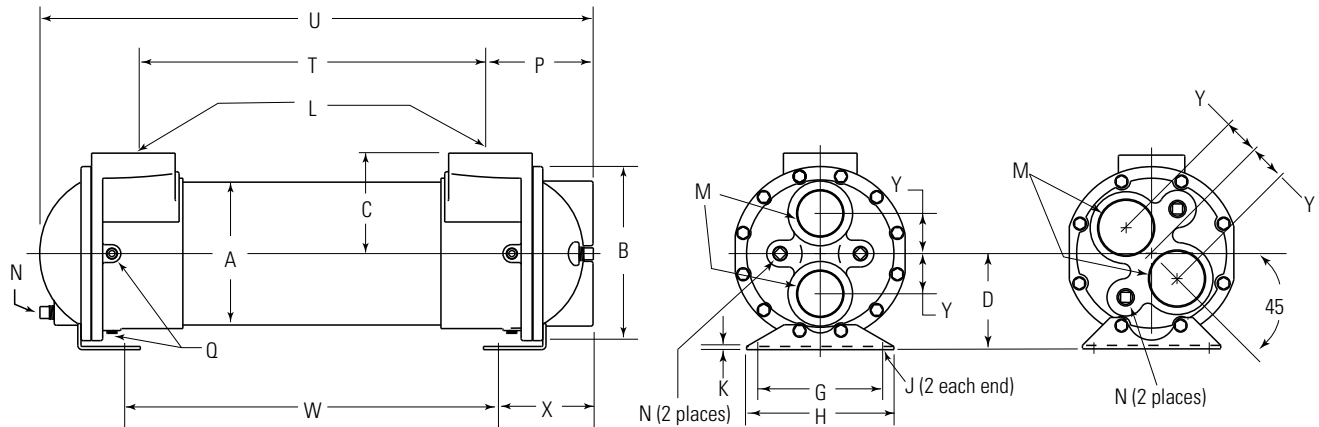

**SSA-1000 &
SSA-1600 Series**

SSA-1200 Series

MODEL	A DIA.	B DIA.	C	D	G	H	J	K	L NPT	M NPT	N NPT	P	Q NPT	T	U	W	X	Y
SSA-1014														11.12	18.50	11.75		
SSA-1024	5.12	6.50	3.62	3.50	4.00	5.00			1.50	1.50	.38	3.69		21.12	28.50	21.75	3.38	—
SSA-1036							.50 x .88	.12						33.12	40.50	33.75		
SSA-1224														20.50	29.00	21.50		
SSA-1236	6.12	7.50	4.25	4.12	5.00	6.00			2.00	2.00		4.25	(6) .25	32.50	41.00	33.50	3.75	—
SSA-1248														44.50	53.00	45.50		
SSA-1260														56.50	65.00	57.50		
SSA-1624											.50			19.25	31.25	20.50		
SSA-1636														31.25	43.25	32.50		
SSA-1648	8.00	9.75	5.62	5.38	7.00	8.25	.62 x 1.12	.19	3.00	3.00		6.00		43.25	55.25	44.50	5.25	—
SSA-1660														55.25	67.25	56.50		
SSA-1672														67.25	79.25	68.50		
SSA-1684														79.25	91.25	80.50		
SSA-1696														91.25	103.25	92.50		

NOTE: We reserve the right to make reasonable design changes without notice. Consult factory. All dimensions are inches.

Model	Surface Area Ft ² 3/8" O.D. Tubes	Tube Count 3/8" O.D.	Weight lbs.
SSA-1014	9.16	80	40
SSA-1024	15.70	80	60
SSA-1036	23.56	80	85
SSA-1224	23.56	120	80
SSA-1236	35.34	120	105
SSA-1248	47.12	120	130
SSA-1260	58.91	120	155
SSA-1624	41.23	210	160
SSA-1636	61.85	210	200
SSA-1648	82.47	210	240
SSA-1660	103.08	210	280
SSA-1672	123.70	210	320
SSA-1684	144.31	210	360
SSA-1696	164.93	210	400

Baffle Spacing

Model	Baffle Spacing
SSA-1014	1.5 & 3
SSA-1024	2 & 4
SSA-1036	2 & 4
SSA-1224	2 & 4
SSA-1236	3 & 6
SSA-1248	3 & 6
SSA-1260	4 & 6
SSA-1624	2 & 6
SSA-1636	3 & 6
SSA-1648	3 & 6
SSA-1660	4 & 6
SSA-1672	4 & 6
SSA-1684	4 & 6
SSA-1696	4 & 6

Dimensions

Four Pass

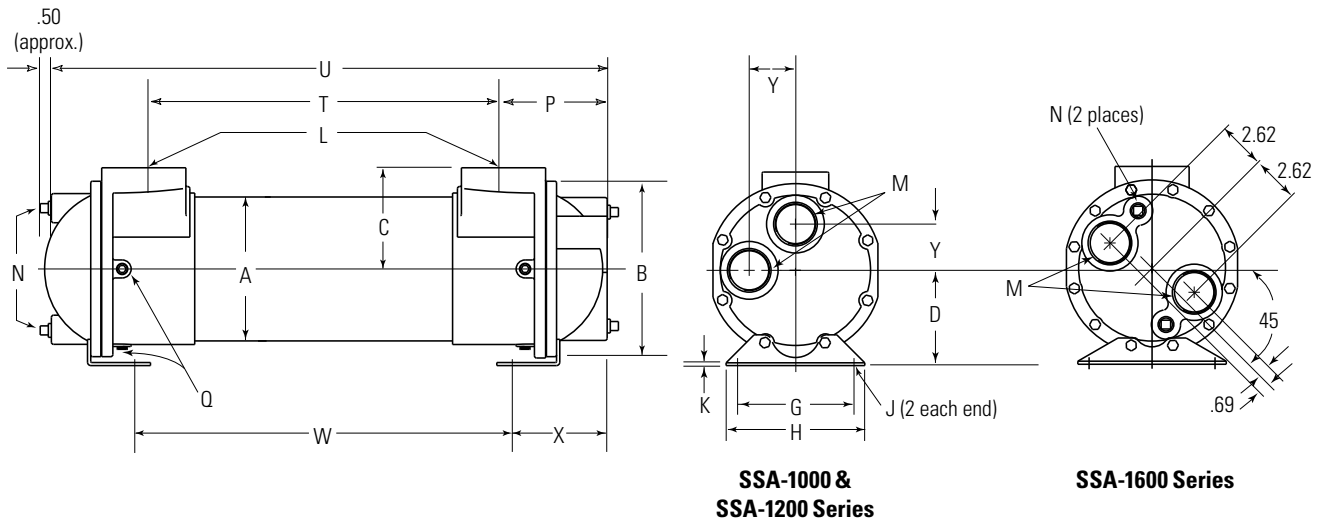

MODEL	A DIA.	B DIA.	C	D	G	H	J	K	L NPT	M NPT	N NPT	P	Q NPT	T	U	W	X	Y
SSA-1014	5.12	6.50	3.62	3.50	4.00	5.00	.50 x .88	.12	1.50	1.00	.38	3.69		11.12	18.38	11.75	3.25	1.69
SSA-1024														21.12	28.38	21.75		
SSA-1036														33.12	40.38	33.75		
SSA-1224	6.12	7.50	4.25	4.12	5.00	6.00			2.00	1.50		4.25	(6) .25	20.50	29.00	21.50	3.75	2.00
SSA-1236														32.50	41.00	33.50		
SSA-1248														44.50	53.00	45.50		
SSA-1260														56.50	65.00	57.50		
SSA-1624	8.00	9.75	5.62	5.38	7.00	8.25	.62 x 1.12	.19	3.00	2.00		6.00		19.25	31.00	20.50	5.25	—
SSA-1636														31.25	43.00	32.50		
SSA-1648														43.25	55.00	44.50		
SSA-1660														55.25	67.00	56.50		
SSA-1672														67.25	79.00	68.50		
SSA-1684														79.25	91.00	80.50		
SSA-1696														91.25	103.00	92.50		

NOTE: We reserve the right to make reasonable design changes without notice. Consult factory. All dimensions are inches.

Maximum Flow Rates

Unit Size	Baffle Spacing	Shell Side (GPM)	Tube Side (GPM)		
			O	T	F
1000	1.5, 2, 3, 4	32, 42, 64, 69	146	73	37
1200	2, 3, 4, 6	51, 77, 103, 115	224	112	56
1600			280	203	101

Caution: Incorrect installation can cause this product to fail prematurely, causing the shell side and tube side fluids to intermix.

Piping Hook-up

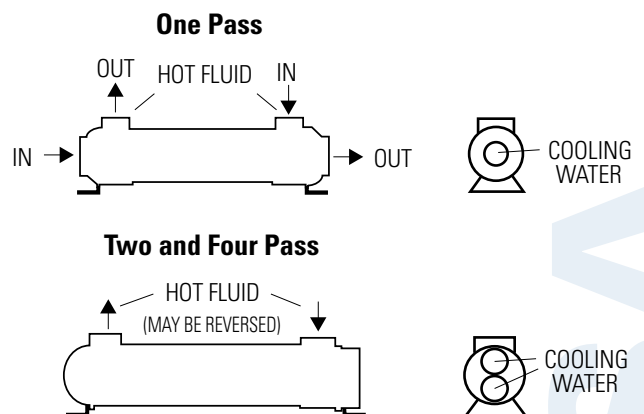

Specific applications may have different piping arrangements. Contact factory for assistance.